

Analysis of Achievable Capacity in Irregularly-Placed High Performance Mesh Nodes

Thomas O. Olwal

CSIR Meraka Institute, Wireless computing and Networking Research Group

CSIR, P. O. Box 395, Pretoria 0001

Tel: +27 12 841 2085, Fax: +27 12 841 4720

E-mail: {tolwal}@csir.co.za

Abstract—Research has shown that the capacity of the wireless mesh network improves with the increase of number of radio interfaces per node and the multiplicity of the non-overlapping frequency channels. Recently, such high performance nodes (HPNs) have been successfully deployed in many areas including the rural South Africa. However, the problem of finding the achievable capacity of such network deployments, taking into account multipath channel links and irregular placements, has been considered a challenge. This paper derives the achievable capacity limit of such HPNs' placements. The analytical results show that the network capacity increases with the irregularity of HPNs placements, the number of antennas as well as the multiplicity of radios per HPN. Compared to the recent analytical results in literature, the HPN showed a superior end to end numerical capacity.

Index Terms—HPNs, Capacity, Irregular Placement.

I. INTRODUCTION

The next generation fixed wireless broadband networks have immensely been deployed as mesh networks in order to provide and extend access to the internet. These networks are characterized by the use of multiple orthogonal channels available within the industrial, scientific and medical (ISM) licensed-free frequency bands. Nodes in the network have the ability to simultaneously communicate with many neighbors or stream different versions of the same data/information using multiple radio devices over orthogonal channels thereby improving effective “online” channel utilization [1]. The ability to perform full duplex communication by individual multi-radio nodes without causing network interference has also been achieved through decentralized transmission power control schemes in [2]-[3]. In [9], authors alluded that multiple radios that receive versions of the same transmission may together correctly recover a frame that would otherwise be lost based on the multipath fading, even when any given individual radio cannot. Many such networks emerging from standards such as IEEE 802.11 a/b/g/n and 802.16 are already in use, ranging from prototype test-beds [4] to complete solutions [5].

The increasing question is how the theoretical capacity of such static multi-radio multi-channel (MRMC) network scales with the node density, irregularity of the terrain and the presence of tree foliage [6]. In their seminal work, Gupta and Kumar [7] determined the capacity of single radio single channel networks. Their findings have been later extended to derive the capacity bounds of the MRMC configurations of a

network scope by Kyasanur and Vaidya [8]. In addition, the link throughput performance parameters in IEEE 802.11 networks have also been discussed in [9]. However, the considered MRMC network architecture has so far been presented with a number of impractical assumptions. The first assumption asserts that the location of nodes and traffic patterns can be controlled in arbitrary networks. The second assumption claims that channel fading can be excluded in the capacity analysis such that each frequency channel can support a fixed data rate. Lastly, nodes are randomly located on the surface of a torus of unit area to avoid technicalities arising out of edge effects. However, in realistic networks, location of nodes is determined by the irregularity of the terrain, the presence of tree foliage [10], and needs and locations of terminal users [11]. Moreover, typical rural based wireless networks can be described by (i) long single hop links, (ii) limited and unreliable energy sources, and (iii) clustered distribution of Internet users [12]. The main problem constitutes the need to increase capacity of community owned existing wireless broadband networks so that multimedia services can be delivered to remote and rural areas without losing connectivity [2].

In response to this need, high performance nodes (HPNs)TM for community-owned wireless mesh networks, have been implemented in most parts of rural South Africa [13]. The innovation as shown in Figure 1 has been developed by the CSIR Meraka Institute and it provides high throughput in mesh networks. The HPNTM is an IEEE 802.11 based multi-interface node made up of three interfaces or radio devices and controlled by an embedded microcontroller technology [11]. To ensure high speed performance, the innovation has the first radio interface card attached to a 5 GHz directional antenna for backhaul mesh routing; the second interface card is connected to a 5 GHz omni-directional antenna for backhaul mesh connectivity and access. The third radio interface card is attached to a 2.4 GHz omni-directional antenna for mesh client access network. As shown in Figure 2, the HPN block diagram has a weather proof Unshielded Twisted Pair (UTP) connector at the bottom of the node that provides Power-Over-Ethernet (PoE) and Ethernet connectivity to the HPN. To attach the HPN to a pole or a suitable structure, a mounting bracket is fixed at the back of the router (See, [11]) for other operational details. The HPNs are often installed on roof tops, street poles and buildings of villages, local schools, clinics, museums and agricultural farmlands.

In this study, the focus will be the determination of the capacity of the terminal backhaul connectivity of the HPNs. The terminal backhaul connectivity offers aggregated traffic

volumes of all flows within the network.

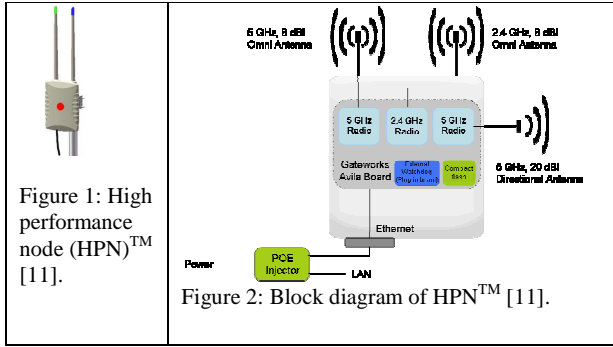

The traffic flows traverse long links between any two HPNs and are faced with severe climatic conditions. Thus, evaluating the capacity limits of such links provides useful inputs toward optimal design of the cross-layer protocols [2]. Figure 3 illustrates the broadband for all (BB4all™) architecture of a single wireless link based on two HPNs (that is, Node A and Node B) with end to end (E2E) Ethernet cable. This architecture forms a single link of the mesh network considered in this paper.

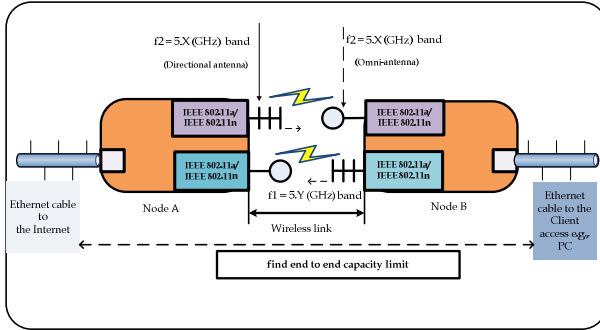

Figure 3: The single link of the BB4all architecture

In spite of recent developments and deployments of HPNs in rural areas, analytical results on achievable capacity of the wireless mesh network is limited. This motivates the derivation of impact of number of interfaces and channels per each HPN on the end to end (E2E) capacity limits of BB4all™ mesh networks. This objective takes into account the fading wireless environment and the dynamics of node density over a fixed deployment area. The study analyses the achievable capacity of a typical placement of HPNs with irregular patterns. The analytical results are compared with the related work in [8] for arbitrary networks.

The study has found that for irregular placement of HPNs, the following analytical results could be obtained: *the upper bound end-to-end capacity limit* of the wireless mesh network is defined as,

$$O\left(Rn\sqrt{\frac{mc}{\delta p}}\right).$$

Here, R is the single link rate in bits/s computed by taking into account multipath effects and the built-in structure of the innovative HPNs, n is the number of HPNs, m is the number of radio interface cards per each HPN, c is the number of frequency channels that do not cause interference in duplex communication, $0 < p < 1$ is the irregularity rate (probability) of the placement of HPNs,

and δ is the HPN distribution density that is varied over a fixed deployment area.

The rest of the paper is organized as follows. Section II provides a description of a typical rural community mesh network in which the BB4all™ architecture proposal can be applied. Section III analyzes upper bounds E2E capacity limits for HPN networks. Section IV furnishes numerical capacity limits and related discussions of a selected real network in a given rural area size. The paper is concluded in Section V, with highlights of the main contribution of this study and future research and development (R&D) perspectives.

II. RURAL COMMUNITY MESH NETWORK: A CASE OF PEBBLES VALLEY MESH

Pebbles valley mesh (PVM) is a typical rural community mesh network that is funded by the International Development Research Centre (IDRC) and is deployed in Mpumalanga province in South Africa [14]. The conventional PVM network, consists of nine (9) single radio nodes, and covers an area of about 15 square kilometers in Masoyi tribal land. The Masoyi tribal land is located at the north east of White River along the road to the Kruger National Park in South Africa. The land is hilly with some large granite outcrops and it has a valley that stretches from the AIDS care training and support (ACTS) clinic and divides the wealthy commercial farms from the poorer Masoyi tribal area. The Masoyi community is underserved with lack of tarmac roads and most houses are lacking running water. However, there is electricity present in Masoyi area. The power outages occur on average one outage in seven days and might even last up to a full day (i.e., 24 hours). The cost of electricity remains an issue to a large population due to the low economic levels in the area.

Figure 4 demonstrates architecture of the PVM network with inclusion of HPNs. The HPN could connect the clinic to surrounding schools, homes, farms and other clinic infrastructure through a mesh network.

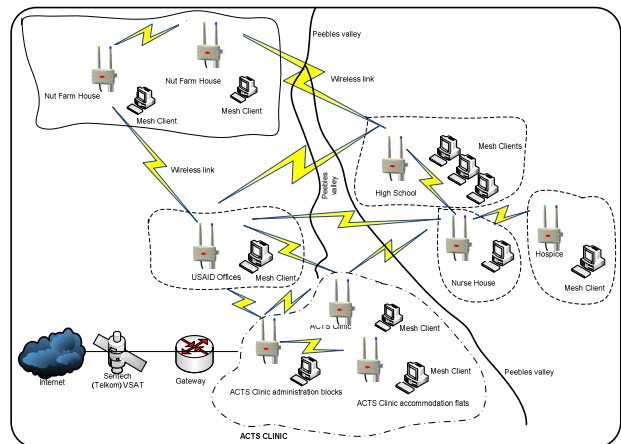

Figure 4: Mesh network at Pebbles valley

Conventionally, the PVM is endowed with VSAT link that provides the network at the clinic with 2 Gbits per month at a download rate of 256 kbps and an upload rate of 64 kbps [15]. The clinic provides 400 Mbps per month available to the single radio mesh network. The single radio mesh has nine users (mesh routers) so that each user (mesh router)

receives about 44.4 Mbps per month on average. This traffic bandwidth drops downstream the network from the satellite gateway to the terminal users. This is due to lack of resiliency against effects of wireless multipath by single radio networks. However, deployment of HPNs is viewed to improve capacity in a multipath environment [16]. The HPNs utilize the multiplicity of the low cost radio devices and non-overlapping channels to improve capacity delivered across the network. Thus, the BB4allTM architecture constitutes a gateway connected to the internet via Sentech VSAT to the Peebles valley or ACTS clinic. Within the ACTS clinic there can be mesh servers, personal computers as the mesh clients and HPNs may be installed to serve as wireless routers that link ACTS clinic accommodation flats to USAID offices about 1 Km away. The HPN link can connect Legogote Hospice and USAID premises about 3.35 Km over the valley via the Nurse house. The link over the valley between the USAID and Sakhile high school is about 2.4 Km. The link from Sakhile high school to the Legogote Hospice is about 4.6 Km, and the distance from high school to the farmers' houses is about 5.55 Km over the Peebles valley. It is also anticipated that the mesh network will expand to public clinics and schools that are farther way even up to 25 Km from the ACTS clinic center in the near future.

III. ACHIEVABLE CAPACITY OF HPN WIRELESS MESH

A. System model of HPNs

In order to analyze the achievable capacity bound for the HPN (the dual channel dual radio) based mesh network we consider a typical static wireless mesh network. Suppose the network is assumed to consist of varying n number of HPNs up to 50 nodes within a fixed area of deployment region (i.e., 5 Km by 5 Km). Also to generalize our derivations and only apply specific cases of PVM later with numerical examples, we employ the approach presented by [8] in order to investigate the impact of number of channels and interfaces on the capacity of multi-channel wireless networks. In our derivations, the term "channel" will refer to a part of frequency spectrum with some specified bandwidth and the term "radio" will mean the network interface card. Let us assume that the HPNs based mesh network has c channels and every node is equipped with m interfaces so that the relation between the number of interface cards and channels is $2 \leq m \leq c$. Each interface card can only transmit and receive data on any one channel at a given time. It is a half-duplex. Thus, the mesh network of m interfaces per node, and c channels will be noted as (m, c) -network. Suppose each channel can support a multi-path dependent data rate of $R = R_{multipath}$, independent of number of non-overlapping channels of the network. Then, the total data rate possible by using all c non-overlapping channels is Rc . The number of non-overlapping channels can be increased by utilizing extra frequency spectrum of the standard technologies. For example, IEEE 802.11a standard technology uses 5 GHz band and has a capability of 24+ non-overlapping channels ($c = 24+$) each of 20 MHz bandwidth size ($W = 20$ MHz). Moreover, the IEEE 802.11n standard technology implements MIMO channels with

bandwidth size of 40 MHz [19]. The theoretical capacity of IEEE 802.11a air interface has been found to be [21]:

$$R_{OFDM/multipath} \approx W \log_2 \left(1 + \frac{P}{(N_0 + I)} \times L^2 \times \frac{K_{antenna} d_0^\alpha}{d^\alpha} \right).$$

Here, P is the power allowed per sub-carrier, L is the number of paths associated to each sub-carrier, N_0 is the noise, I is the interference and α is the path loss exponent. $K_{antenna}$ denotes the combined antenna gain which the product of the transmitter and the receiver antenna gains, d_0 is the reference distance and d as the distances between HPNs. On the other hand, the IEEE 802.11n air interface has been modeled using statistical MIMO channels that capture key elements of the spatial multiplexing. The derived single channel capacity over multipath fading has been found to be [20]:

$$R_{multipath} = \log_2 \left(1 + SINR_j \times \left\| \sum_i^{multipaths} a_i^b \mathbf{e}_r(\Omega_{ri}) \mathbf{e}_t(\Omega_{ii})^* \right\|^2 \right),$$

where a_i^b , $\mathbf{e}_r(\Omega)$ and $\mathbf{e}_t(\Omega)$ are the channel gains, units spatial signatures for the receiver and transmitter antennas in the direction of cosine Ω (the angular separations)[10].

B. Capacity limit for irregular placement

Consider the topology of HPNs that reflects typical wireless mesh network set-ups in rural and remote areas where inter node distance is large and the landscape affects network performance. To avoid interference, it is assumed that no any two HPNs are placed within a radius less than 400 m at the edge and less than 700 m toward the centre of the deployment area. However, between any two HPNs the largest separation distance is allowed as much possible as the size of the area can accommodate. Consequently, Figure 5 indicates one of the possible settlement distribution patterns of the Internet users in community based networks such as the case of Peebles valley mesh (PVM) networks.

Theorem 1: The E2E upper bound on capacity of a statically assigned channel network of type (m, c) -arbitrary and irregular placement of HPNs is derived to be,

$$\lambda n \bar{L} = O \left(R n \sqrt{\frac{mc}{\delta p}} \right) \text{ bit-meters/sec, when } \frac{c}{m} = O(n).$$

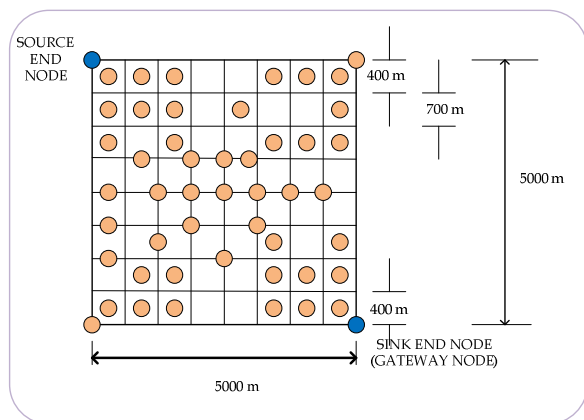

Figure 5: Irregular placement of HPNs

Proof: Let us consider that in irregular and static networks, the node density δ varies over space (i.e., an area) but stays constant at any given time. Suppose the irregularity rate

(probability) of HPN placement is, $0 < p < 1$, then the area A is defined as $A = \frac{n}{\delta p}$. Capacity of the network is then proportional to the δp for an irregular placement with n as the number of nodes. Define the capacity of each channel, R as $R = kA = k \frac{n}{\delta p}$ for some constant k (in bits/s/square meters). Suppose each source HPN can generate packets from higher layers protocol at a rate of λ bits/sec and the mean separation distance between the source and destination HPN pairs is denoted as \bar{L} meters (via multiple hops), then the E2E network capacity of the network is [7]:

$$\lambda n \bar{L}, \text{ bit-meters/sec.} \quad (1)$$

The expression in (1) is however, shown without taking into account the number of frequency channels, interference, path loss effects and number of interface cards. Furthermore, to relate this high level network capacity with the actual number of hops in a multi-hop wireless network requires that the overall bits transported in the network be evaluated as follows. Suppose bit b , $1 \leq b \leq \lambda n$ (bits/sec), traverses $h(b)$ hops on the path from its source to its destination, where the h th hop traverses a distance of r_b^h , then the overall bits transported in the network in every second is summed and is related to (1) as:

$$\lambda n \bar{L} \leq \sum_{b=1}^{\lambda n} \sum_{h=1}^{h(b)} r_b^h, \text{ bit-meters/sec.} \quad (2)$$

The inequality in (2) holds since the mean length of the line joining the source and destination, is equal to at most the distance traversed by a bit from its sources to its destination [8].

Additionally, HPNs have m interfaces per node and with a data rate of R possible per channel. Thus, the total bits per second that can be transmitted by all interfaces in the network and all channels is at most $\frac{Rnm}{2}$ (transporting a bit across one hop requires two interfaces, one each at the transmitting and the receiving nodes). Consequently, the relation between a single channel single link rate, the number of interface cards per link, the number of nodes in the network, and the total number of hops traversed by all bits in every second is given by,

$$X \leq \frac{Rmn}{2}, \text{ bits/sec} \quad (3)$$

It should be noted that under the interference protocol model [7], a transmission over a hop of length r in a path loss link is successful only if there can be no active transmitter within a distance of $(1+\Delta)r$. In IEEE 802.11a/b/g/n standards the medium access control (MAC) layer protocols execute carrier sense multiple access with collision avoidance (CSMA/CA) mechanism that ensures that this condition is always satisfied. Figure 6 depicts this type of collision avoidance mechanism. To illustrate this concept further, suppose node A is transmitting a bit to node B, while node C is simultaneously transmitting a bit to node D and both the sessions are over a common frequency

channel, W . Then, using the interference protocol model and the geometry sufficient for successful reception, node E cannot transmit at the same time with A and C. That is,

$$d(C,B) \geq (1+\Delta)d(A,B) \text{ and } d(A,D) \geq (1+\Delta)d(C,D). \quad (4)$$

Adding the two inequalities together, and applying the triangle inequality to (4), we can obtain the inequality in (5),

$$d(B,D) \geq \frac{\Delta}{2}(d(A,B) + d(C,D)). \quad (5)$$

Therefore, in collision avoidance (CSMA/CA) principle, expression (5) can be viewed as each hop covering a disk of radius $\frac{\Delta}{2}$ times the length of the hop around each receiver.

As shown in Figure 6, the total area covered by all hops must be bounded above by the total area of the deployment (domain, A). The separation distance between receiver B and transmitter C is at least $(AB + \Delta AB)$ and that of transmitter A and receiver D is at least $(CD + \Delta CD)$.

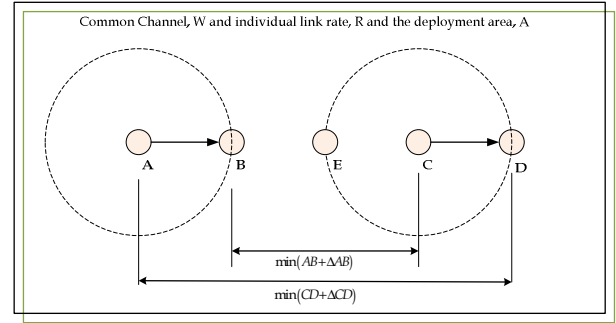

Figure 6: Geometry of HPNs

From the geometry of Figure 6, the summation over all channels (which can potentially transport Rc bits per second) will yield the constraint formulated as,

$$\sum_{b=1}^{\lambda n} \sum_{h=1}^{h(b)} \frac{\pi \Delta^2}{4} (r_b^h)^2 \leq ARc, \quad (6)$$

$$\sum_{b=1}^{\lambda n} \sum_{h=1}^{h(b)} \frac{1}{X} (r_b^h)^2 \leq \frac{4ARc}{\pi \Delta^2 X}.$$

Since the expression on the left hand side in (6) is convex, one obtains,

$$\left(\sum_{b=1}^{\lambda n} \sum_{h=1}^{h(b)} \frac{1}{X} r_b^h \right)^2 \leq \sum_{b=1}^{\lambda n} \sum_{h=1}^{h(b)} \frac{1}{X} (r_b^h)^2. \quad (7)$$

Therefore, from (6) and (7) one gets,

$$\sum_{b=1}^{\lambda n} \sum_{h=1}^{h(b)} r_b^h \leq \sqrt{\frac{4ARcX}{\pi \Delta^2}}. \quad (8)$$

Let $X = \sum_{b=1}^{\lambda n} X(b)$ as the number of bits transmitted by all nodes in a second (including bits forwarded). From (8), it can be found that

$$\sum_{b=1}^{\lambda n} \sum_{h=1}^{h(b)} r_b^h \leq \sqrt{\frac{4ARRnmc}{2\pi \Delta^2}} \text{ or } \sum_{b=1}^{\lambda n} \sum_{h=1}^{h(b)} r_b^h = \lambda n \bar{L}. \quad (9)$$

So that,

$$\lambda n \bar{L} \leq R \sqrt{\frac{2Anmc}{\pi \Delta^2}} = Rn \sqrt{\frac{2mc}{\delta p \pi \Delta^2}}. \quad (10)$$

$$\lambda n \bar{L} = O\left(Rn \sqrt{\frac{mc}{\delta p}}\right), \text{ bit-meters/s.} \quad (11)$$

Here, R is a dependent variable that varies with the number of multiple paths, number of antennas and antenna gains [10], [20]. This variable is computed using parameters mentioned in Section IIIA. ■

IV. NUMERICAL EXAMPLES USING PEBBLES VALLEY MESH

A. Conditions and results of E2E achievable capacity

In our numerical computations, the IEEE 802.11a/n HPNs were placed as guided by the pattern depicted in Fig. 5. The capacity for single links of different distances was computed using data obtained from datasheets [19]. Capacity results for single links and the *proof of the theorem 1* were subsequently used to compute the E2E achievable capacity for the HPNs. Tables 1 and 2 show the E2E numerical values of achievable capacity computed right from the Ethernet at one end of the network to Ethernet at the other end of the network. The results assume that the radio interfaces $m=2$, the orthogonal channel $c=2$, the deployment area $A = 5000m \times 5000m$ and the bandwidth $W=20 Mhz$ and the carrier frequency of 5.85 GHz.

Suppose that Carrier sense multiple access with collision avoidance (CSMA/CA) protocol is employed in order to identify node pairs that can simultaneously transmit [1]. In this protocol, neighbors of both the intended transmitter and receiver have to refrain from both transmission and reception at the same time. Practically, we can let $\Delta=10\%$ of one hop distance to be sufficient enough to prevent neighboring nodes from transmitting on the same sub channel at the same time. This study also assumed an optimized link state routing (OLSR) protocol that proactively maintains fresh lists of destinations and their routes [14]. These routing tables are periodically distributed in the network. The protocol ensures that a route to a particular destination is immediately available. Couto et al. [17] proposed an expected transmission count (ETX) metric to calculate the expected number of retransmissions that are required for a packet to travel to and from a destination. ETX metric is adopted in this study as a default routing metric to determine the amount of successful packets at any receiver node from a transmitting neighbor within a window period. ETX metric is also viewed as a high-throughput path metric for multi-hop wireless mesh network [17]. Using such information, we can illustrate the E2E capacity limit with a practical example of network deployments. In particular, consider the following cases: irregular pattern when $n=10$ and when $n=50$. Assume that the average distance of source-destination pair is 6505 m. The value enables the computation of achievable capacity over direct LOS path (i.e., without multi-hops) between the source and destination nodes. Nodes are assumed to be placed irregularly with a

rate (probability) p . Note that $0 < p < 1$. The choice of p depicts the degree of irregularity, with smaller values of p depicts more irregular placement.

Due to space constraints, p was taken arbitral as 0.9 in this study and the corresponding E2E capacity was tabulated (See Tables 1 and 2).

Table 1: IEEE 802.11a of HPNs of BB4all™ architecture

Placement in a 5 km x 5 km area	No. of HPNs	Achievable link capacity (Mbps)	E2E achievable capacity (Mbps)
$p = 90\%$	10	R(2100 m) = 281.12	0.5473
$p = 90\%$	50	R(700 m) = 376.22	0.9827

Table 2: IEEE 802.11n of HPNs of BB4all™ architecture

Placement in a 5 km x 5 km area	No. of HPNs	Achievable link capacity (Mbps)	E2E achievable capacity (Mbps)
$p = 90\%$	10	R(2100 m) = 722.24	1.4061
$p = 90\%$	50	R(700 m) = 912.44	2.3832

Table 3 illustrates the achievable E2E numerical capacity result of our analysis compared to the closely related analytical results by [8]. The comparison was performed when irregularity rate was 0.9, number of HPNs in the fixed area was 10 and the achievable link capacity for 10 HPNs' network was 722.24 Mbps. It should be noted that the experimental result was only for the purpose of demonstrating the analytical capacity performance of BB4all™ innovation in the simplest case.

Table 3: Comparable of E2E achievable capacity

Dual-radio dual-channel mesh network	Consists of IEEE 802.11n HPNs: irregularly placed	Arbitrary network of dual radio dual channel (Kyasaur and Vaidya, 2005)
E2E capacity limit (of 10 nodes) in Mbps in a 5 km x 5 km	1.4061	0.01

B. Discussions on E2E achievable capacity

It should be noted from Tables 1 and 2 that in a fixed area of 5 km by 5 km, the E2E achievable capacity evaluated shows that there is lower capacity when number of HPNs is ten than when the number is 50 in irregular placements. The main reason is that a series of long links created between any two immediate nodes degrades the achievable E2E capacity. For instance, at ten HPNs in the fixed sized network, the hop distances are much larger than the case for 50 HPNs. In each hop, the propagating signal faces path loss effects due to terrain irregularity, foliage and wireless medium conductivity. The implication is that signal traversing longer hop distances are faced with higher attenuation and lower E2E capacity than signal propagating over shorter hops. With the same number of nodes and fixed area of deployment, the inter hop distances where nodes occur will be much smaller by 10% than in regular HPN placements when $p = 100\%$. But shorter hops imply higher capacity if and only if there is no interference. Moreover, according to Li et al. [18], increasing or keeping constant the number of

nodes placed in a fixed area automatically increases or keeps constant the average node density. The average node density is inversely proportional to the E2E capacity according to *Theorem 1*. Thus, a lower average density in an irregular node placement for the same number of nodes will yield a higher E2E capacity if and only if the area of deployment is fixed or decreased. Using similar argument, when values of p is decreased (i.e., 0.8, 0.7, 0.6, etc), the average δ decreases proportionately and if the area of deployment is fixed or reduced then for the same number of nodes, the capacity will increase.

It was also noted that network throughput dropped significantly from source HPN to the destination HPN or the gateway. In particular, the drop was by about 99% across 3 long distance hops and by about 99% across 3 long distance hops considering irregularly deployed HPNs from Tables 1 and 2, respectively. The general explanation is that, the channel gain drops with increase in propagation distance, and there are also overhead losses associated with medium access control (MAC) and the multi-hop routing such that the number of packets sent is not equal to the number of packets received successfully. Despite this observation, HPNs derived from IEEE 802.11n radios have a better E2E capacity achievable mainly due to the MIMO technologies that are capable of combating multi-path fading [20].

In arbitral network, with a combined antenna gain of 9dBi, hop distance of 700 m, bandwidth of 20 MHz, transmitted power output of 100 mWatts and 1e-10 Watts, the conventional analytical results of [8] was compared with the HPNs of the BB4all™ architecture. Data from Table 3 shows that HPNs of the latter with special radios and antenna arrangements is more superior to the HPNs with standard antenna gains. While all cases considered dual radio dual channel specifications, the HPNs have higher throughput antenna configurations than the work proposed by [8].

V. CONCLUSIONS AND FUTURE WORK

The BB4all™ architecture makes use of omni-directional antennas to maintain mesh connectivity, while directional antennas support information relay over long distances with high power gains. It was confirmed analytically and numerically that increasing the number of interfaces per HPN and channels in the network does increase the achievable E2E capacity in any arbitral network placement. One of the contributions of this study was the determination of the capacity of the innovation constructed to improve performance of the commercially available WLAN devices. The pillar of innovation was that increasing the antenna gains could improve capacity of real networks even without increasing the power settings of the transmitter.

Other possible explorations of increasing capacity of community networks (i.e., Peebles valley mesh in South Africa) include the utilization of unused frequency (TV white space) spectrum and green energy foraging from the wireless environment. The TV white spaces spectrum fosters high capacity signal transmissions over long distances in rural terrains. Thus, cognitive and foraging radio techniques are promising tools toward spectrum and energy efficient network management for the next billion Internet users. It should also be noted that, although the theoretical

derivations were applied to the PVM network, they could also be applied to other rural deployments as well.

VI. REFERENCES

- [1] M. Kodialam, and T. Nandagopal, "Characterizing the capacity region in multi-radio multi-channel wireless mesh networks," *MobiCom'05*, Aug 28-Sept2, 2005, Cologne, Germany.
- [2] T. O. Olwal., *Decentralised dynamic power control for wireless backbone mesh networks*, PhD Thesis, University of Paris-EST and Tshwane University of Technology, May 2010.
- [3] T.O. Olwal, et al., "Optimal control of transmission power management in wireless backbone mesh networks," In: *Wireless Mesh Networks*, Funabiki, N (Eds). pp. 3-28, In Tech, ISBN: 978-953-307-519-8, Croatia.
- [4] J. Eriksson, Agarwal, S., Bahl, P., and J. Padhye, "Feasibility study of mesh networks for all-wireless offices," In *Proc. MobiSys'2006*, June 19-22, 2006, Sweden, pp. 69-82, ISBN: 1-59593-195-3.
- [5] Mesh Dynamics Inc., "Wireless mesh networks that scale like switch stacks," Available at <http://www.meshdynamics.com>, 2010.
- [6] A. L., Intini, "OFDM wireless networks: Standard IEEE 802.11a". *Technical report at the University of California Santa Barbara*, 2000.
- [7] P. Gupta and P.R. Kumar, "The capacity of wireless networks," *IEEE Transactions on Information Theory*, Vol. 46 (2), pp. 388-404, 2000; ISSN: 0018-9448.
- [8] P. Kyasanur and N. H. Vaidya, "Capacity of multi-channel wireless networks: impact of number of channels and interfaces," *Technical Report of Dept.CS, University of Illinois at Urban-Champaign*, March 2, 2005.
- [9] L. Berthilsson and A. E. Pascual, "Link performance parameters in IEEE 802.11: How to increase the throughput of a wireless long distance link," In: *White paper*, April 2007.
- [10] D. Tse and P. Viswanath, *Fundamentals of wireless communication*, Textbook Chapters 5 and 7, University of California Berkley, 2005.
- [11] I. Makitla, A. Makan, and K. Roux, K. "Broadband provision to underprivileged rural communities." In *Proc. CSIR 3rd Biennial Conference 2010*. Also available at www.csir.co.za :
- [12] J. Ishmael, S. Bury, D. Pezaros, and N. Race, "Deployment rural community wireless mesh networks." *IEEE Internet Computing* Vol. (2): 22-29; DOI: 1089-7801/08/2008 IEEE, 2008.
- [13] K. Roux, et al., "Broadband for all (BB4all)™," *CSIR Science Scope, Magazine*, Vol. 3(3) January 2009, pp. 16-17.
- [14] D. Johnson, "Evaluation of a single radio rural mesh network in South Africa," *Proc. ICICT*, Bangalore India, December 2007.
- [15] D. Johnson, and K. Roux, "Building rural wireless networks: lessons learnt and future directions," *Proc. of 2008 ACM WWWNDR*, San Francisco, California, USA, 19 Sept. 2008, pp. 17- 22.
- [16] BelAir Networks, "Capacity of wireless mesh networks: understanding single radio, dual radio and multi-radio wireless mesh networks," In: *White paper*, pp. 1-16, 2006.
- [17] D.S.J. De Couto, D. Aguayo, J. Bicket, and R. Morris, "A high throughput path metric for multi-hop wireless routing." *Wireless Networks Journal*, Vol. 11 (4), pp. 419-434, 2005.
- [18] J. Li, C. Blake, D. S. J. De Couto, H. I. Lee, and R. Morris, "Capacity of Ad hoc Wireless Networks," *Proc. of MobiCom Conference*, July 2001, Rome, Italy, pp. 61-69.
- [19] Cisco Systems Inc., *Channels and maximum power settings for Cisco Aironet lightweight access points*. pp. 1-130, No: OL-11321-08, 2011.
- [20] M. Franceschetti, M. D. Migliore, and P. Minero, "The capacity of wireless networks: information-theoretic and physical limits." *IEEE Trans. on Information Theory*. Vol. 55 (8), pp. 3413-3424, 2009.
- [21] T.O. Olwal, M. Masonta, F. Mekuria and K. Roux, "Achievable capacity limit of high performance nodes for wireless mesh networks," Accepted In: *Wireless Mesh Networks*, Krendzel (Eds), In Tech 2012.

Thomas Olwal received his undergraduate degree in 2003 from the University of Nairobi, M Tech from TUT in 2006, MSc. from ESIEE-Paris in 2007, DTech from TUT in 2011 and PhD from University of Paris-Est in 2010. His research interests include green radio networks, wireless network capacity analysis, and energy foraging & spectrum management.